



CARREFFE

DATI TECNICI - TECHNICAL DATA-DONNEES TECHNIQUE-DATOS TECNICOS

AFC Srl Handling Equipment

20122 Milano - V.le Regina Margherita 30 +39 02 98876001

29017 Fiorenzuola (PC) - Via Gobetti 4 +39 0523 349769

info@afhandling.com

www.afhandling.com



CP 06 GL - PRLI

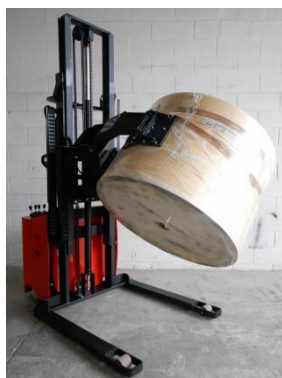
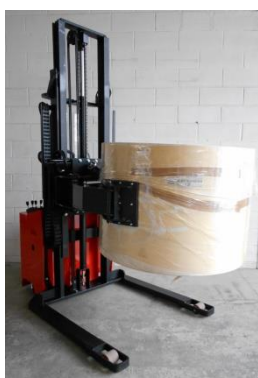
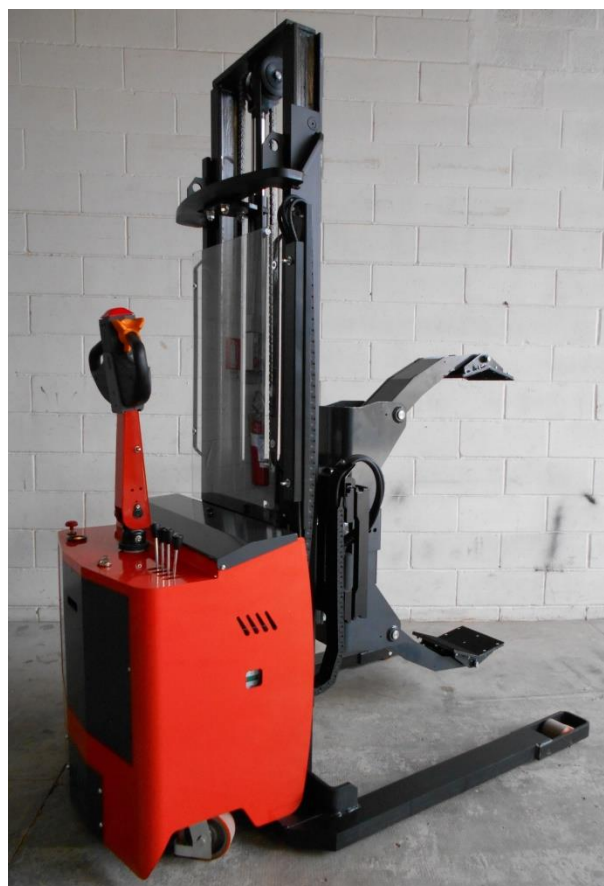

CP 06 GL-PRLI

	h3 mm	h1 mm	h4 mm
CP 06.16	1560	2075	
CP 06.25	2460	1850	3080
CP 06.29	2860	2050	3480

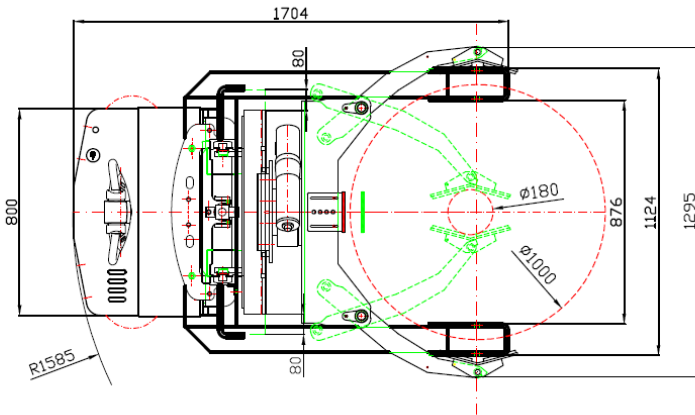
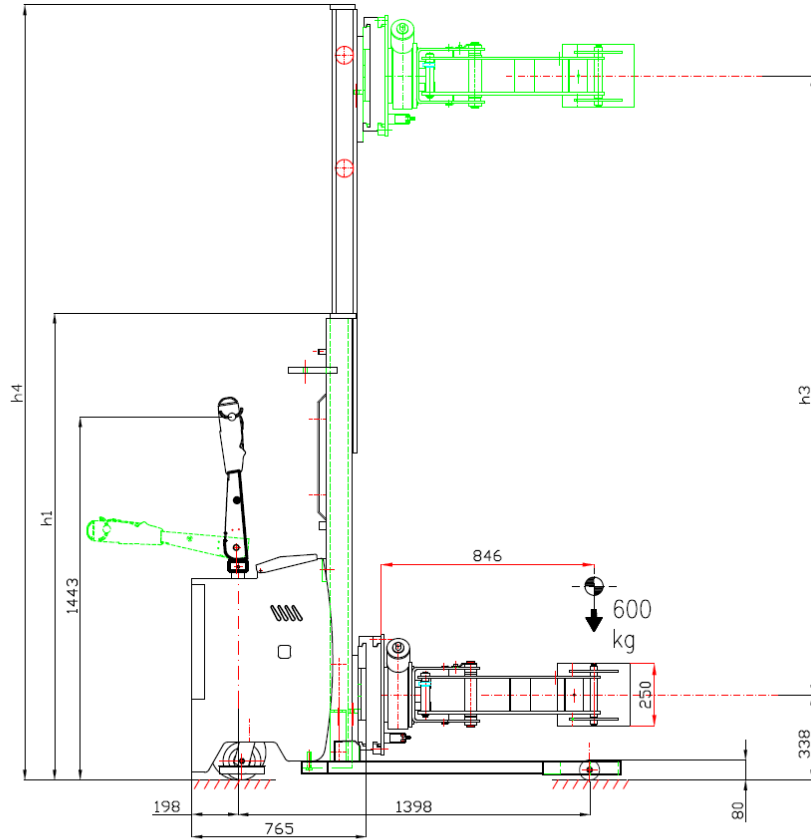
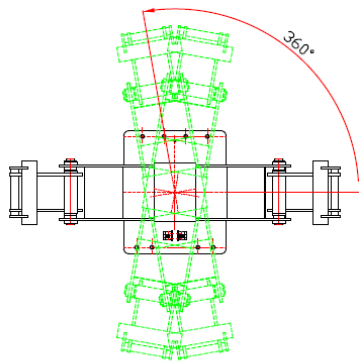
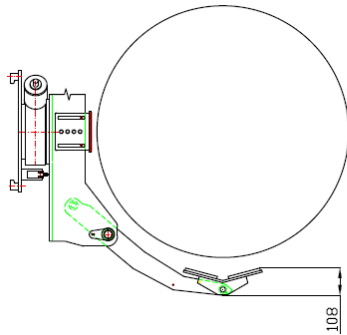

IDENTIFICAZIONE	IDENTIFICATION	IDENTIFICATION	CARACTERISTICAS	
Modello	Manufacturer's type	Modèle	Modelo	CP 06 GL-PRLI
Guida	Drive	Conduite	Accionamiento	Electric (batt)
Tipo di operazione	Type of operation	Type d'opération	Conduccion	Pedestrian
Portata	Load capacity	Capacité	Capacidad de carga	Q = 0,6 (t)
Baricentro	Load centre	CDG	Centro de gravidad	846 mm
Peso batt. incl.	Service weight incl. batt.	Poids avec batterie	Peso propio con bateria	980 Kg
RUOTE/TELAIO	WHEELS/CHASSIS	ROUES/CHASSIS	RUEDAS/CHASSIS	
Ruote (ant/post)	Tyres	Roues	Bandajes (del/atr)	poly/poly
Dim. Ruote ant.	Tyres size, front	Roues avant	Dim. Ruedas del.	80x70 mm
Dim. Ruota trad.	Tyres size, drive	Roue motrice	Dim. Rueda tracciòn	250x100mm
Dim. Ruote addiz.	Additional wheels	Roues supplement.	Dim. Ruedas estabilizad.	150x50mm
N. ruote (x=motrice)	Wheels N. (x=driven)	N. roues (x=motrice)	Cantidad (x=motrices)	Nr. 4 +2/1x
PRESTAZIONI	PERFORMANCE DATA	PERFORMANCES	RENDIMIENOTOS	
Velocità trazione	Traction speed (load/unl.)	Vitesse tract. (a/s charge)	Velocidad de traslaciòn (c/s)	3,5 / 4,5 Km/h
Pendenza massima	Max gradient	Max pente	Pendientes	6 / 10 %
Freno	Service Brake	Frein de service	Frenado	Electric
MOTORE	E-MOTOR	MOTEUR	ACCIONAMIENTO	
Motore trazione	Traction motor	Moteur de traction	Motor de tracciòn	DC 1,7 kW
Motore sterzo	Steering motor	Moteur direction	Motor de direcciòn	-
Motore sollevamento	Lifting motor	Moteur de lévage	Motor de elevaciòn	DC 2,2 kW
Batteria	Battery	Batterie	Bateria	24/240 V/Ah
Peso batteria	Battery weight	Poids batterie	Poid bateria	210 Kg
Raddrizzatore	Charger	Chargeur incorporé	Cargador	24/25 V/A