



DATI TECNICI - TECHNICAL DATA-DONNEES TECHNIQUE-DATOS TECNICOS

AFC Srl Handling Equipment

20122 Milano - V.le Regina Margherita 30 - +39 0298876001

41012 Carpi - Via Bari 12 - +39 0599771262

info@afchandlingequipment.com www.afchandlingequipment.com

ABL.X-ATR/CBF



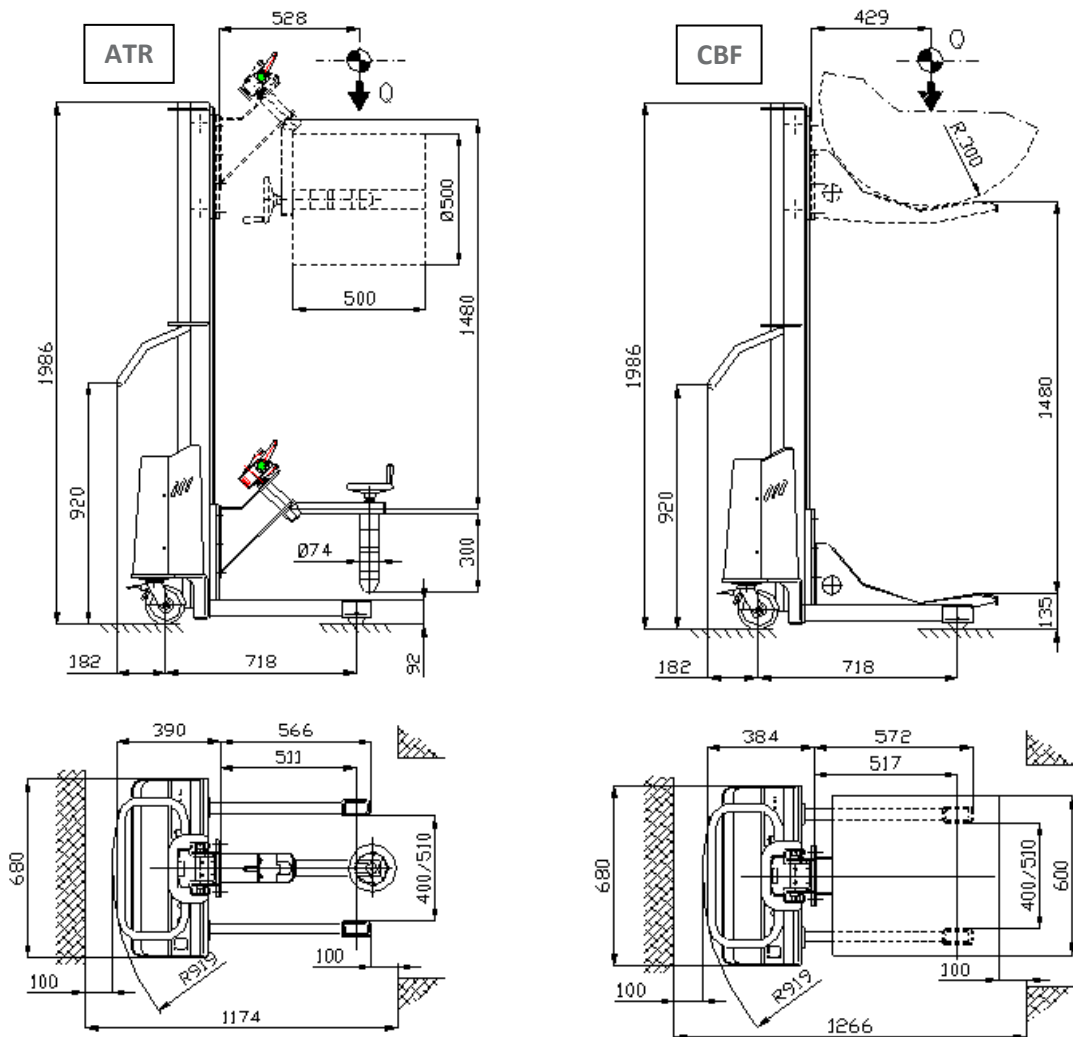

IDENTIFICAZIONE	IDENTIFICATION	IDENTIFICATION	CARACTERISTICAS	
Modello	Manufacturer's type	Modèle	Modelo	ABLX-ATR/CBF
Guida	Drive	Conduite	Accionamiento	Manual
Tipo di operazione	Type of operation	Type d'opération	Conduccion	Pedestrian
Portata	Load capacity	Capacité	Capacidad de carga	150/300 Q(kg)
Peso batt. incl.	Service weight incl. batt.	Poids avec batterie	Peso propio con batería	160 Kg
RUOTE/TELAIO	WHEELS/CHASSIS	ROUES/CHASSIS	RUEDAS/CHASSIS	
Ruote (ant/post)	Tyres	Roues	Bandajes (del/atr)	poly/nylon
Dim. Ruote ant.	Tyres size, front	Roues avant	Dim. Ruedas del.	85x40 mm
Dim. Ruote post.	Tyres size, rear	Roues arrière	Dim. Ruedas traseras	150x40mm
N. ruote (x=motrice)	Wheels N. (x=driven)	N. roues (x=motrice)	Cantidad (x=motrices)	N. 2+2
PRESTAZIONI	PERFORMANCE DATA	PERFORMANCES	RENDIMIENTOS	
Velocità trazione	Traction speed (load/unl.)	Vitesse tract. (a/s charge)	Velocidad de traslación (c/s)	Manual
Velocità discesa	Descent speed (load/unl.)	Vitesse despence (a/s charge)	Velocidad de descenso (c/s)	0,10 ms
Velocità sollevamento	Lifting speed (load/unl.)	Vitesse levage (a/s charge)	Velocidad de elevación (c/s)	0,18 ms
Freno	Service Brake	Frein de service	Frenado	Pedal
MOTORE	E-MOTOR	MOTEUR	ACCIONAMIENTO	
Motore sollevamento	Load capacity	Moteur de levage	Motor de elevación	0,5 kW
Batteria	Battery	Batterie	Bateria	2x12/56 v/Ah
Peso batteria	Battery weight	Poids batterie	Poid batería	2x18 Kg
Raddrizzatore	Charger	Chargeur incorporé	Cargador	HF 24/10 V/A